

PRORIL

60Hz

Rugged, reliable and cost effective, the Titan series pumps deliver excellent performance and serve a wide range of tough dewatering applications like mines, construction site, rental applications and other demanding industries.

Dewatering Pump

TITAN 4110/6110

Heavy Duty Dewatering Pump



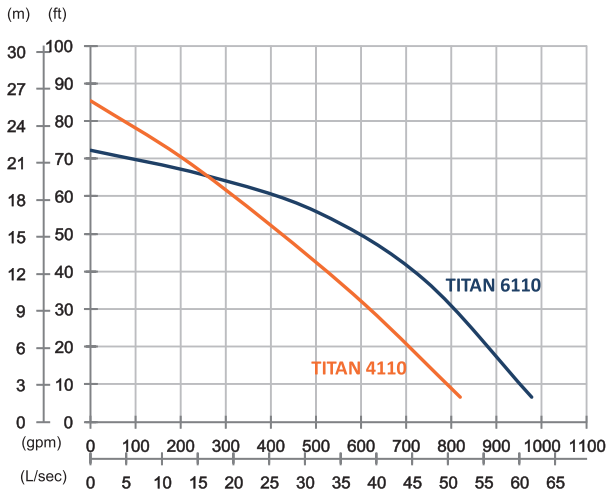

	TITAN 4110	TITAN 6110
OUTPUT	15 HP (11 kW)	15 HP (11 kW)
OUTLET	4" (100 mm)	6" (150 mm)
SOLID PASSAGE	1" (25 mm)	1.4" (35 mm)
Weight	430 lbs/195 kg	432 lbs/196 kg
HEAD	Rated: 52 ft, 16 m Max: 85 ft, 26 m	Rated: 56 ft, 17 m Max: 72 ft, 22 m
FLOW	Rated: 396 gpm, 25 L/s Max: 819 gpm, 51.7 L/s	Rated: 502 gpm, 31.7 L/s Max: 977 gpm, 61.7 L/s

Pump Type		Electric Submersible Pumps
Motor	Phase	3-Phase
	Type	Induction Motor
	Poles	4 Pole (1750 rpm)
	Insulation	Class F
	Protector	Circle Thermal Protector
	Starter	D.O.L.
Lubricant		Food Grade (ISO VG32)
Specs.	Impeller Type	Opened
	Shaft Seal	Double Mechanical Seal
		Silicon Carbide VS Ceramic/Carbon
	Bearings	C3 Shielded ball bearings
	Cable	CSA-Certified PVC Jacketed Cables
33 ft (10 m) or longer upon request		
Materials	Pump Casing	Ductile Iron
	Impeller	Chromium Iron
	Motor Frame	Gray Iron
	Motor Shaft	Stainless Steel
	Strainer	Carbon Steel
Max. Liquid Temperature		40°C (104°F)
Max. Submersion Depth		20 m (66 ft)
pH Range		pH 5 - pH 8

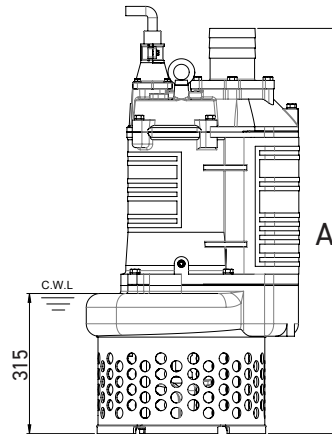
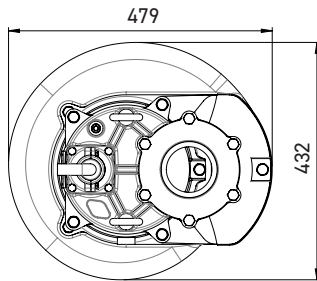

unit : mm

C.W.L. : Continuous running water level

	A
TITAN 4110	910
TITAN 6110	922